

Micro Ingredient System



APEC - Automated Process Equipment Corporation



Dependability

The APEC Micro Ingredient System is designed to achieve accurate weighing of your ingredients time after time

Advantages

Rectangular bins with chamfered corners means no corners for material to stick to

A pneumatic clean out enhancement on the scale tub insures no product carry over

The tight bin cluster takes up less valuable floor space

Optional TSS feeders provide repeatable accuracy to 0.01 lbs



Standard Features

Removable 6 or 10 cu. Ft. capacity stainless steel bins with hinged and gasketed covers

Stainless steel feeder screws with variable pitched flighting

Power cords with twist lock plugs

Control panel mounted on the frame and completely wired at the factory. Includes AC inverter, motor contactors, overload, PLC for two speed operation and two speed control MMI on the panel for individual feeder control.

Tubular frame with telescoping legs

Roll over scale tub or optional indexing scale vessel



APEC - Automated Process Equipment Corporation

1201 North Fourth Avenue
Lake Odessa, Michigan 48849

Phone: 616-374-1000
Fax: 616-374-1010

Email: sales@apecusa.com
Website: www.apecusa.com

Micro Ingredient System Specifications

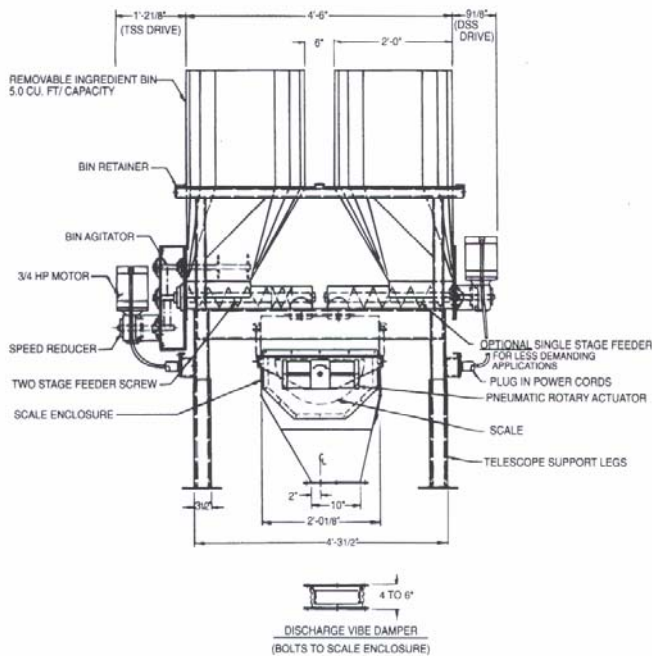
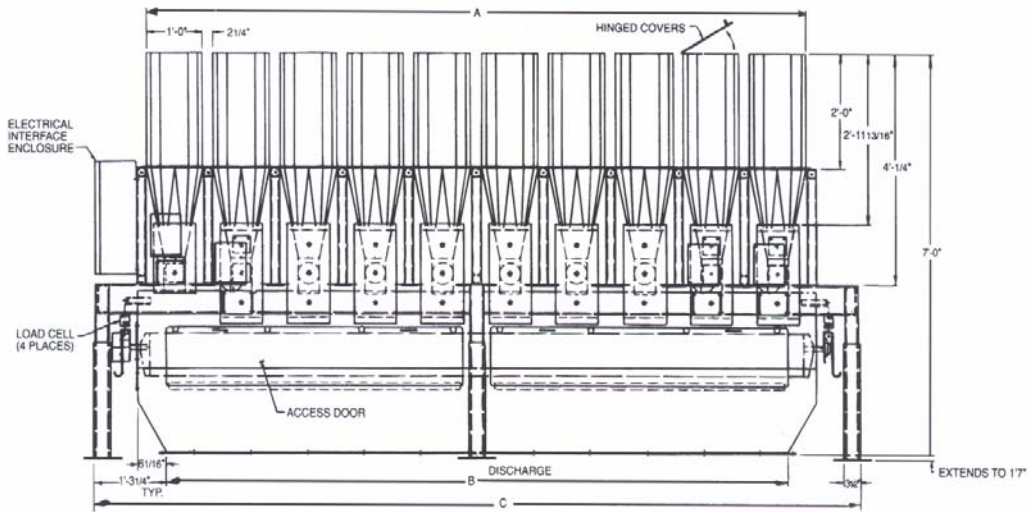

Dimensions				
Bins	A	B	C	Weight
6	3'-4 1/2" 102.9	2'-8 1/4" 66.70	5'-2 1/4" 159.4	2300 1045.4
8	4'-6 1/4" 139.1	3'-10 1/2" 118.1	6'-5" 208.3	2900 1318.2
10	5'-9" 175.3	5'-0 1/4" 154.3	7'-7 1/4" 31.8	3500 1590.9
12	6'-11 1/4" 211.4	6'-3" 190.5	8'-9 1/4" 267.9	4100 1863.6
14	8'-1 1/2" 247.6	7'-5 1/4" 226.7	9'-11 1/4" 304.2	4800 2181.8
16	9'-3 1/4" 283.8	8'-7 1/2" 262.9	11'-2" 340.4	5400 2454.4
18	10'-6" 320.0	9'-9 1/4" 297.8	12'-4 1/4" 376.5	6000 2727.3
20	11'-8 1/4" 356.2	11'-0" 335.3	13'-6 1/2" 412.7	6600 3000.0

Inches/Pounds
Centimeters/Kilograms

Available Options

- Bin Extensions To Increase Capacity
- Bin Inventory (Bins On Load Cells)
- Electric Bin Lid Locks
- 50 Hz Motors
- Explosion Proof Motors
- Dust Collection Pick Up Point
- Feeder Shut Off Gate
- CEMA IV Finish On Bins And Feeder Screws

Contact APEC Today For Your Micro Ingredient System Needs

Phone: 616-374-1000

Fax: 616-374-1010

Sales—sales@apecusa.com

<http://www.apecusa.com>