

# Powder Feeder



## APEC - Automated Process Equipment Corporation



### Description

Powder feeder designed for metering dry additives into the Mistcoater or any other machine in your system.

Powder feeders are available in **Loss In Weight** or **Volumetric** configurations.

### Volumetric Features

- 6.7 cubic foot capacity ingredient hopper
- Hinged lid with locking handle, gas springs and prox switch for refill indication
- Bolted in expanded metal trash screen
- Feeder screw sized to your rate needs
- 1-1/2 hp feeder screw gearmotor drive
- U-trough with removable cover
- Mechanical bin agitator with separate 3/4 hp gearmotor drive prevents material bridging
- Sheave and timing belt drive components

### Loss In Weight Features

Same as Volumetric above **plus** :

- Platform scale with floor support frame
- Loss In Weight Control panel which can be mounted on the floor support frame or independent of the feeder

### Available Options

- 50 Hz Motors
- Explosion Proof Motors
- Washdown Duty Motors and Reducers
- Corrosion Resistant Bearings
- CEMA IV or Food Grade Finish
- Motion Indicators
- Lexan Viewing Window
- Plastic Ingredient Bins and Vibratory Feeders



## APEC - Automated Process Equipment Corporation

1201 North Fourth Avenue  
Lake Odessa, Michigan 48849

Phone: 616-374-1000  
Fax: 616-374-1010

Email: [sales@apecusa.com](mailto:sales@apecusa.com)  
Website: [www.apecusa.com](http://www.apecusa.com)

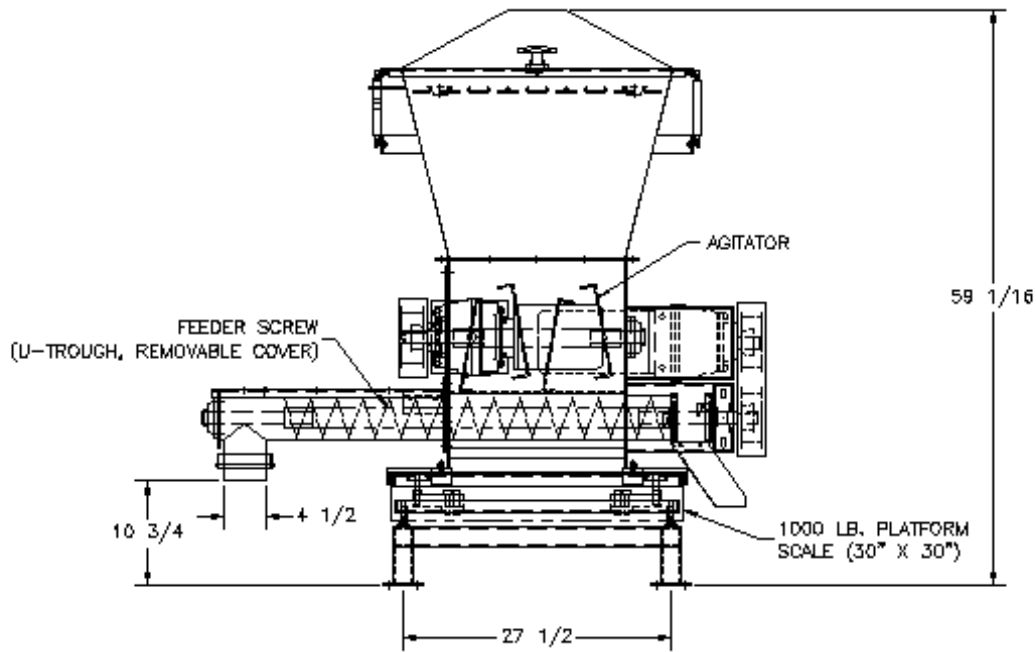
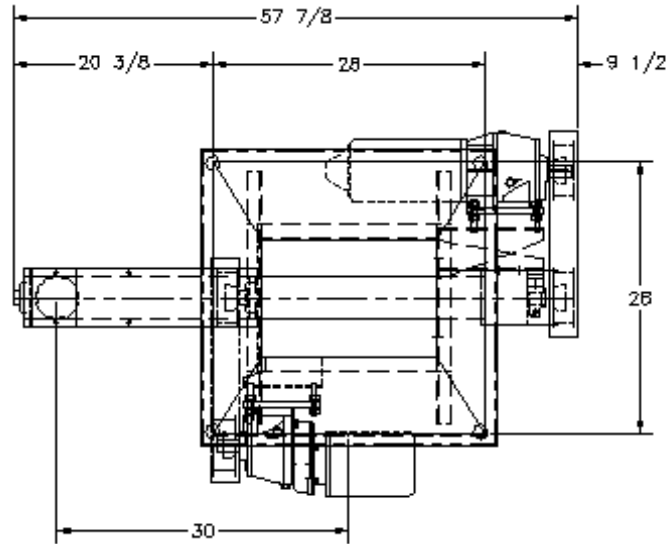

### Additional Options

- Mild or stainless steel construction
- Floor support frame with casters
- Extended feeder screw
- Fixed lid for pneumatic refill

**Contact APEC Today For Your Powder Feeder Needs**

**Phone: 616-374-1000  
Fax: 616-374-1010**

Sales—sales@apecusa.com

<http://www.apecusa.com>

